

TURNED TRIVET
TOP PATTERN

Remove sha

TurnedTrivets 70

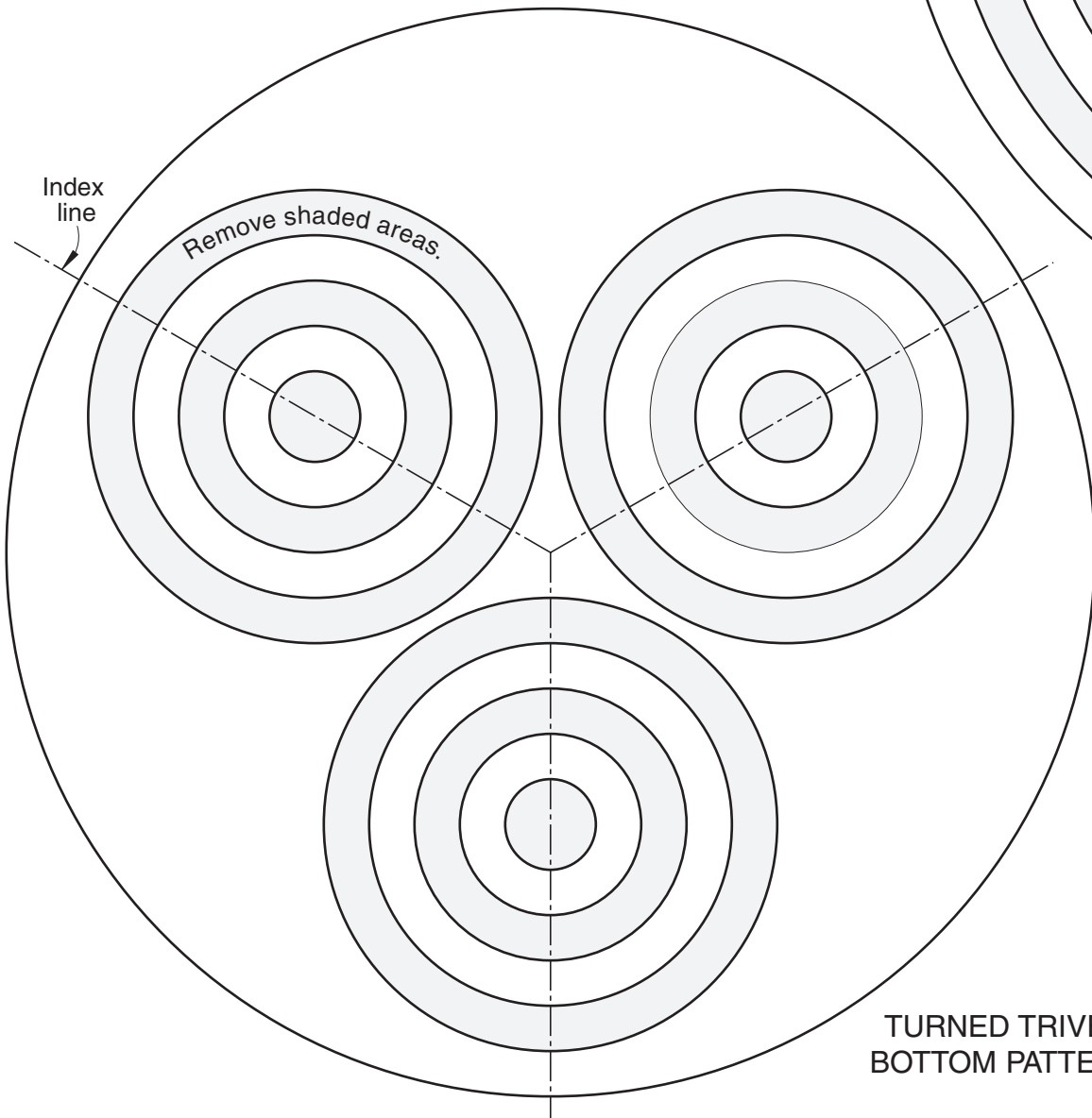

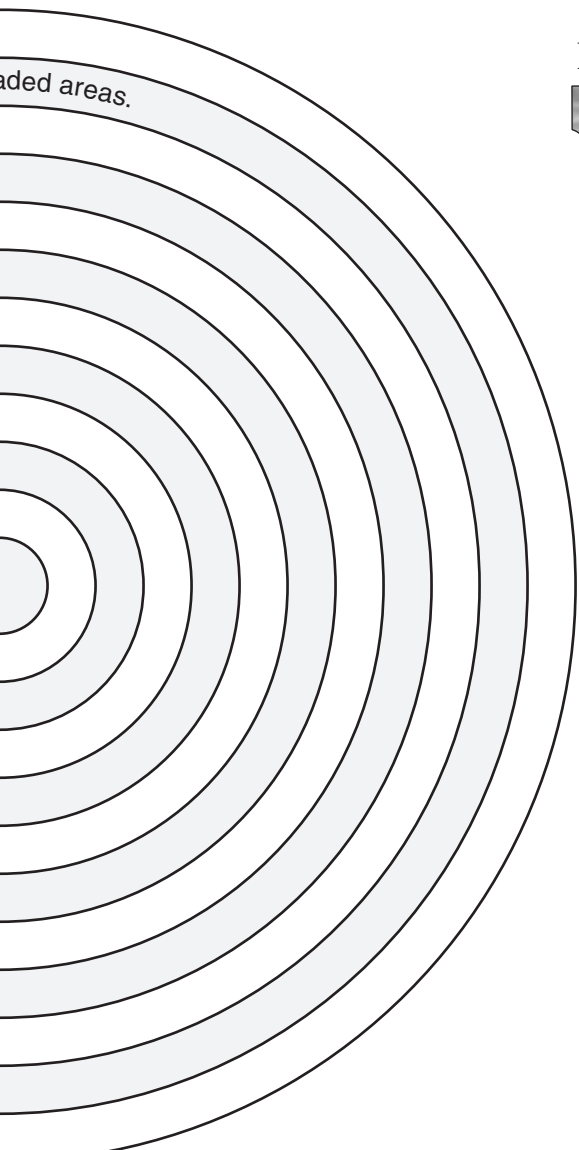

Better Homes and Gardens®

WOOD PATTERNS®

March 2004

For your woodworking convenience

Issue 154

Dear Reader: As a service to you, we've included full-size patterns on this insert for irregular-shaped and intricate project parts. You can machine all other project parts using the Materials List and the drawings accompanying the project you're building.



© Copyright Meredith Corporation, 2004. All rights reserved. Printed in the U.S.A. Meredith Corp., the publisher of *WOOD Patterns*®, allows the purchaser of this pattern insert to photocopy these patterns solely for his/her own personal use. Any other reproduction of these patterns is strictly prohibited.

Turned Trivets 70

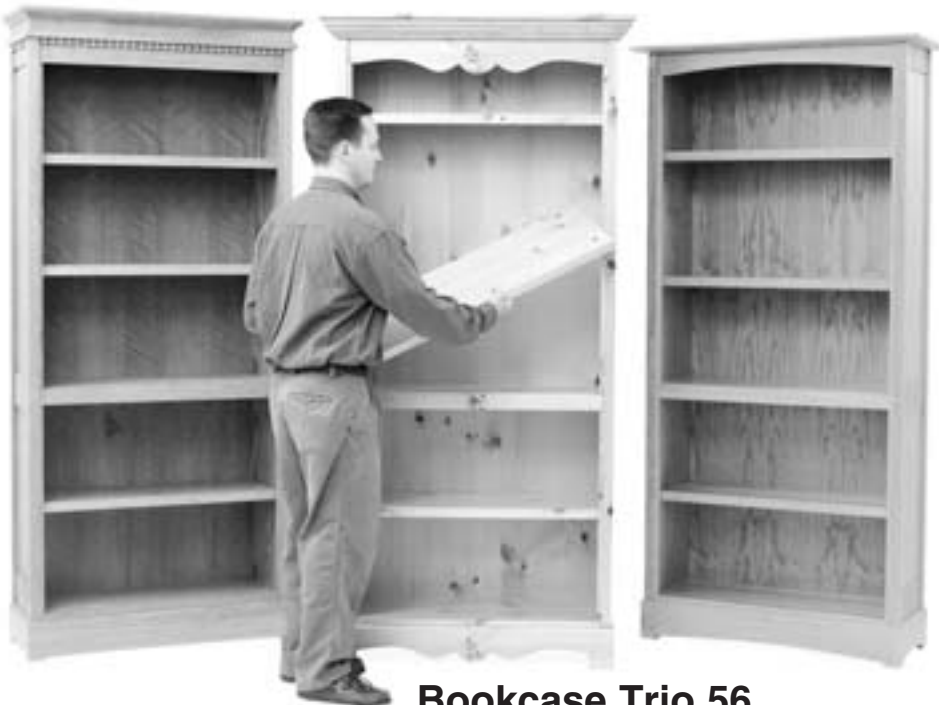

Bookcase Trio 56



Traditional Chair 80

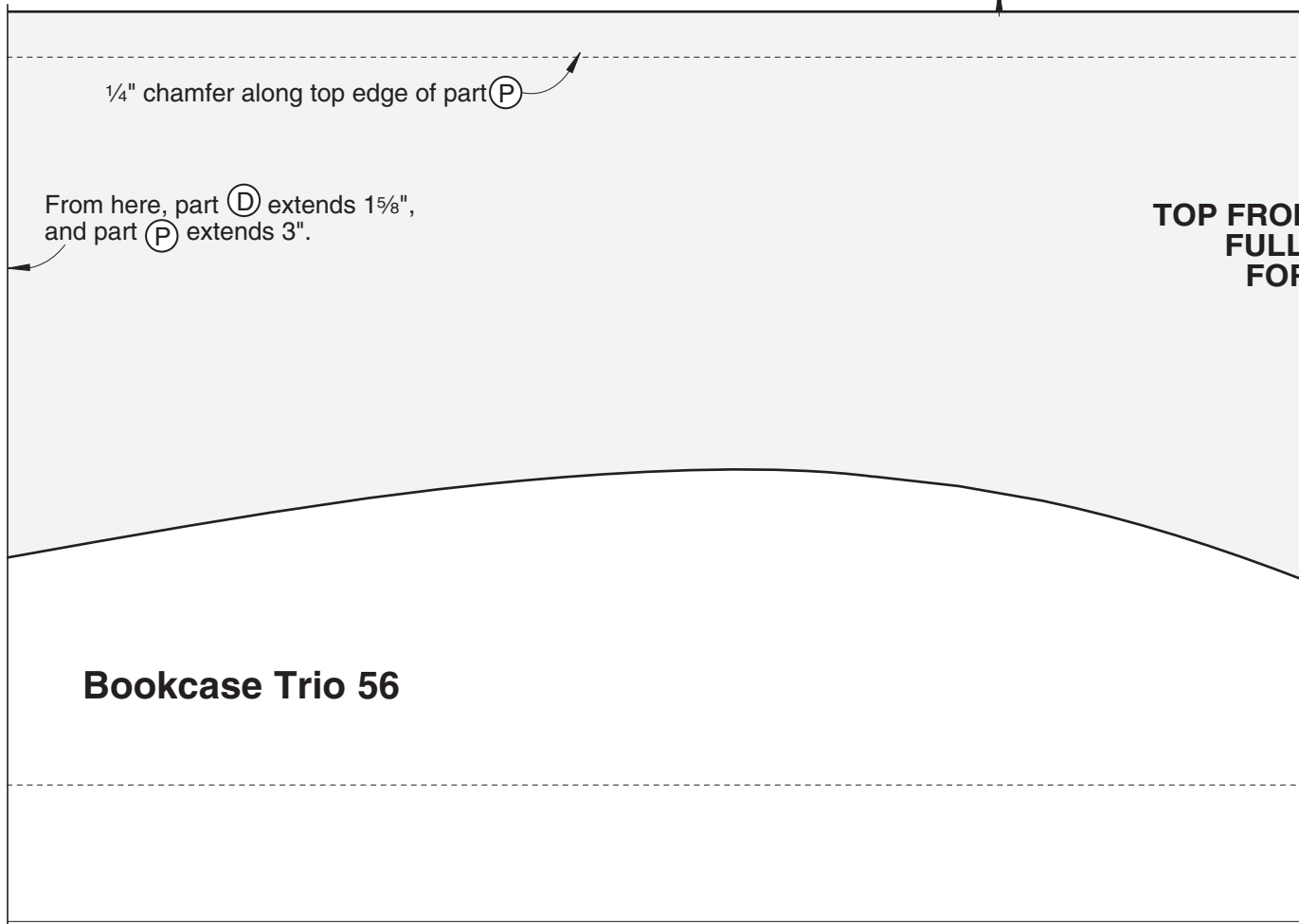
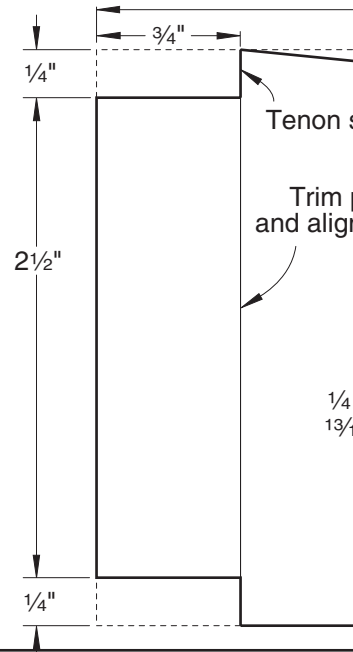
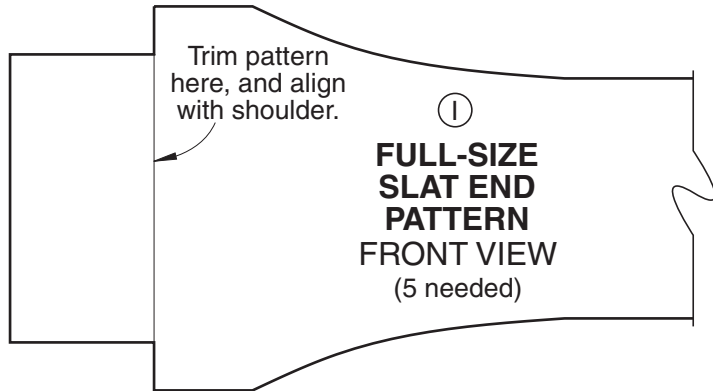
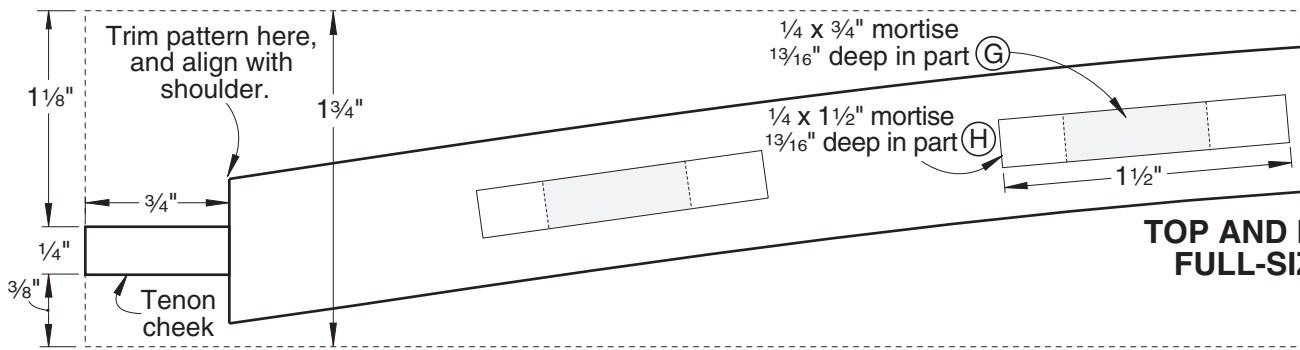

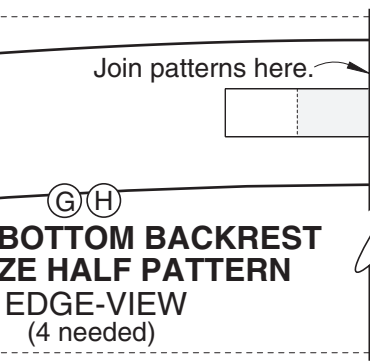

Traditional Chair 80

