

WOODStore.net

Browse more than 1000 plans, projects, books, techniques, & more

Thank You!

Thank you for ordering a WOOD® magazine download. We hope you enjoy being part of our online experience and that you have fun expanding your woodworking skills.

Please remember that this copyrighted material is for your use only. It is unlawful to share this file with someone else or to reprint it in any form.

Bill Krier
Editor in Chief, WOOD magazine

Adobe Acrobat Reader Troubleshooting Guide

If you can read this page, your Acrobat Reader program is working correctly! But you may still have problems or specific issues, such as printing and saving your downloadable file.

My printer won't print the text correctly
Almost all printing problems are due to not enough free system resources memory. The files are very memory intensive because they include graphics, text, and photos. Close all other programs/applications and print directly out of the Acrobat Reader program, not your Web browser.

Patterns are not printing full-size
Make sure your printer is set to print at 100 percent and that "print to fit" is not checked. These settings are selected in the printer setup or printer options.

I can't save my file now that it's downloaded
You must save the plan when you download the file. Download the file again, except this time try right-clicking on the red download button. A menu window will open. Select "Save target as" or "Save link as" to save the file to your hard drive. Once saved, you can open it up with Adobe Acrobat Reader.

For more details on using Adobe Acrobat Reader please visit our online help section at:
<http://www.woodstore.net/clicherforde.html>

WOOD Store Customer Favorites

Shop Tools & Accessories



Indoor Furniture



Outdoor Furniture

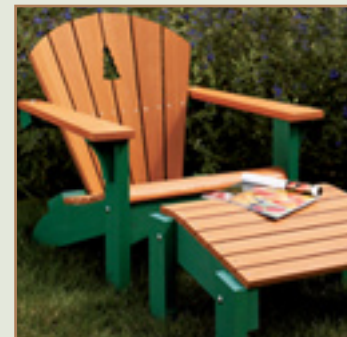

Mission Furniture

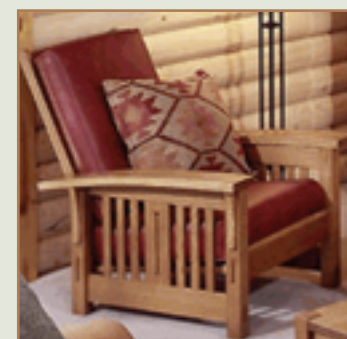

Visit the WOOD Store at:
WOODStore.net



a gem of a jewelry box



Looking to craft a unique item to delight someone special? This stylish chest, made with eye-catching curly maple and wengé, is just the ticket. Though the project looks sophisticated, the construction's surprisingly simple, thanks to the straightforward dado, rabbet, and groove joinery, and a full-size pattern for quickly contouring the legs. Anxious to get started but need materials and/or hardware? Relax—you'll find a source for kits, listed at the end of this article, to get you quickly into the shop.

Start with the striking contrasting-wood case

1 To form a 5⁷/₁₆"-wide contrasting-wood blank for the case sides (A) and back (B), cut a 4⁷/₁₆×30" piece from ¾"-thick curly maple and a 1×30" piece from ¾"-thick wengé. (Feel free to use other woods of your choice.) Edge-glue the pieces together, keeping the faces and ends flush. Although a hard and dark wood, which contrasts nicely with the curly maple, wengé splinters and chips easily. To avoid these problems, see the **Shop Tips**, below.

2 After the glue dries, scrape off the squeeze-out. Then joint one face, and plane the blank to ½" thick. Now crosscut the two 7½"-long sides (A) and 13"-long back (B) from the blank.

3 From ¾"-thick curly maple planed to ½" thick, cut the top front rail (C) to the size listed in the **Materials List** page 11. Then, from ¾"-thick wengé planed to ½" thick, cut the bottom front rail (D) to size.

4 Using a standard ⅛"-kerf blade in your tablesaw, cut on the *inside* face of the sides (A), back (B), and top front rail (C) a ⅛" groove ¼" deep 1" from the *top* edge to fit your ⅛" hardboard for the top panel (E), where shown on **Drawing 1** and dimensioned on **Drawing 2**. Then cut the same size groove ¾" from the

bottom edge of the sides, back, and bottom front rail (D), where shown, to receive the bottom panel (E). Now cut the two inner ⅛" grooves ¼" deep on the *inside* face of the sides only, where dimensioned on **Drawing 2**, to receive the ⅛" hardboard drawer runners (G), where shown on **Drawing 1**.

5 Fit your tablesaw with a ½" dado blade, and attach an auxiliary extension to the miter gauge and an auxiliary fence to the rip fence. Then cut a ¼"-deep rabbet across both ends of the back (B), top front rail (C), and bottom front rail (D) on the *inside* faces, where shown on **Drawing 2**, to receive the sides (A).

Note: If your dado blade does not produce a clean, flat-bottomed surface, cut the rabbets a hair less than ¼" deep. Then sand them smooth and to final depth using a block of wood wrapped with 150-grit sandpaper. This will ensure tight case joints that are visible with the lid open. You also can use this technique when cutting the rabbets in the legs (H).

6 Mark the centers and ends of the curves along the bottom edges of the sides (A), back (B), and bottom front rail (D), where dimensioned on **Drawing 2**. Bending a fairing stick to the marked points, draw the curves.

Then bandsaw and sand the curves to shape. (For a free fairing stick plan, go to woodmagazine.com/fairing.)

7 From ⅛" hardboard, cut the top and bottom panels (E) to 7½×12½". Then, from ¾"-thick wengé resawn or planed to ¼" thick, cut the two front fillers (F) to ½×3⅜".

8 Dry-assemble and clamp together the sides (A), back (B), top and bottom front rails (C, D), top and bottom panels (E), and front fillers (F), and verify the parts fit together correctly. Disassemble the case, and make any needed adjustments.

9 Apply glue to the rabbets in the back (B). Assemble the sides (A) to the back with the top and bottom edges flush. Then slide the top and bottom panels (E) into the grooves to square the assembly, and clamp it together. Next, glue and clamp the top and bottom front rails (C, D) to the case, as shown in **Photo A**, flush with the top and bottom edges of the sides (A). After the glue dries, glue and clamp the front fillers (F) in position, where shown on **Drawing 1**, flush with the outside faces of the sides.

10 From ⅛" hardboard, cut the four drawer runners (G) to size to fit the grooves in the sides (A). Insert the runners in the grooves without glue for now.

SHOP TIPS

How to work successfully with wengé

Wengé (pronounced *when-gay*), an exotic wood from equatorial Africa, has a beautifully straight but coarse grain structure that makes it prone to splintering and chipping if you don't take these precautions while working with it:

- Check the ends of the stock for cracks before cutting it. Look carefully because the dark coffee color makes it difficult to see defects. Depending on the extent and location of any cracks found, you may need to select another workpiece. Although the fine, black veins that run through the wood can look like cracks, don't jump to conclusions. If you don't see cracks, the wood is likely okay.
- For the cleanest cuts, use sharp carbide-tipped blades and bits and a zero-clearance insert. Be sure to back up all cuts with scrap to avoid splintering and splitting, such as that shown at *right*.
- Ease all edges by lightly sanding with 220-grit sandpaper.
- When bandsawing contours to shape, stay at least ¼" away from the marked cutlines, and then sand to the lines.
- After crosscutting, remove any whiskers from the ends of the wood with sandpaper rather than your fingers. This will avoid additional splintering and prevent possible skin irritation as well.
- When sanding, start with 150 grit and work up to finer grits. Starting with a coarser grit creates scratches that take more sanding to remove.



Next up: the shapely legs and leg fillers

1 From $\frac{3}{4}$ "-thick wengé, cut two $1\frac{1}{16}\times 28$ " pieces to form a blank for the legs (H). Laminate the pieces together. Then plane the blank to $1\frac{1}{16}$ " thick. Using a dado blade in your tablesaw, cut a $\frac{1}{2}$ " rabbet $\frac{1}{2}$ " deep along the blank, where shown on **Drawing 1a**.

2 Crosscut the blank to form four $6\frac{3}{16}$ "-long legs. Next, make four copies of the leg full-size pattern on *page 13*. Spray-adhere a pattern to the *outside* faces of each leg, folding the pattern where shown.

3 With a leg positioned with the "Cut 1" side of the pattern faceup and using a guide block for safety, as explained in the **Shop Tip**, below, bandsaw and sand to the curved pattern line. Reattach the cutoff to the leg with double-faced tape. Then reposition the leg on the guide block with the "Cut 2" side of the pattern up. Bandsaw and sand to shape. Remove the attached cutoff and tape. Repeat to shape the remaining legs.

4 Test-fit the legs on the case, and verify tight-fitting joints. Then, to glue the legs in place, flush with the case top edge, where shown on **Drawing 1**, position the case on a flat

worksurface with the top edge down. Now glue and band-clip the legs to the case, flush with the worksurface.

5 From $\frac{3}{4}$ "-thick wengé planed to $\frac{1}{2}$ " thick, cut a $\frac{1}{2}\times 8$ " workpiece to form the leg fillers (I). Crosscut four $\frac{3}{4}$ "-long fillers from the piece. Now glue and clamp the fillers to the inside of the legs (H), tight against the bottom edges of the case.

Make the beautiful lid, and hinge it to the case

1 From $\frac{3}{4}$ "-thick wengé planed to $\frac{1}{2}$ " thick, cut the breadboard ends (J) for the lid panel (K) to size.

2 Edge-join $\frac{3}{4}$ "-thick curly maple to form a $9\frac{3}{8}\times 13\frac{1}{2}$ " blank for the lid panel (K). After the glue dries, scrape off the squeeze-out. Plane the lid panel to $\frac{1}{2}$ " thick. Now crosscut and rip the panel to the finished size of $8\frac{7}{8}\times 12\frac{3}{4}$ ". Sand the panel to 220 grit.

3 Using a dado blade in your tablesaw and a zero-clearance insert, cut a centered $\frac{1}{4}$ " groove $\frac{3}{8}$ " deep along the *inside* edge of the breadboard ends (J), where shown on **Drawing 3**. Raise the blade to $\frac{3}{4}$ ". Now cut a centered groove along the *front* edge of the panel (K) to receive the handle (L).

4 Adjust your dado blade. Then cut $\frac{4}{8}$ " rabbets $\frac{1}{8}$ " deep on each end of the panel (K), forming $\frac{1}{4}$ " tongues $\frac{3}{8}$ " long to fit the grooves in the breadboard ends (J).

5 Chuck a 45° chamfer bit in your table-mounted router. Then rout a $\frac{3}{16}$ " chamfer along the back bottom edge of the panel (K), where shown on **Drawings 3** and **3a**. (The chamfer provides clearance for the knuckles of the lid hinges.)

GLUE THE FRONT RAILS TO THE CASE

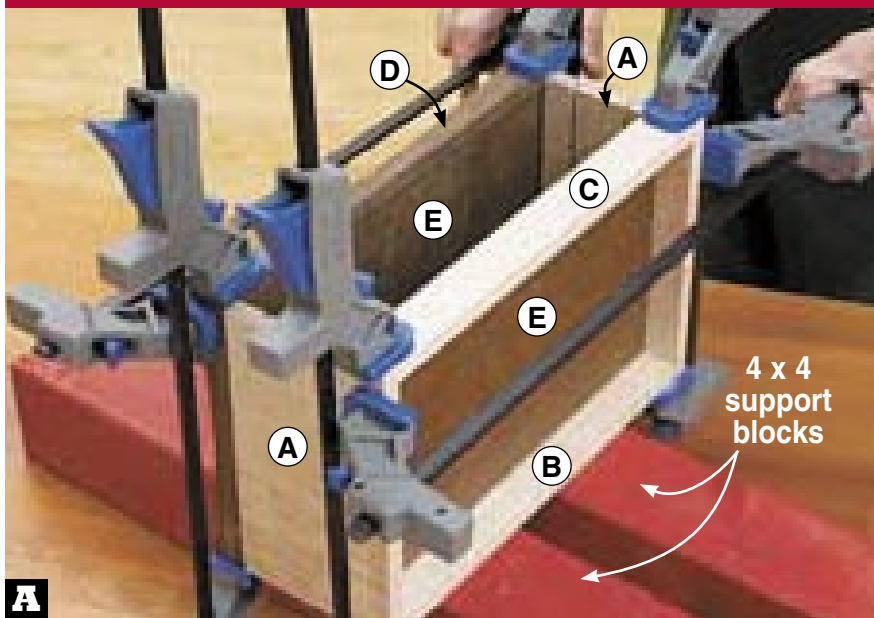

With the case on 4x4 support blocks for clamp clearance, glue and clamp the top and bottom front rails (C, D) to the sides (A).

SHOP TIP

Bandsaw small parts safely using a guide block

To keep fingers out of harm's way and maintain safe control when bandsawing small parts, double-face-tape a guide block at least 3" wide and of suitable thickness and length to the parts. Using a jewelry box leg (H) as an example, cut a $3\times 6\frac{3}{16}$ " piece from $\frac{1}{2}$ "-thick scrap or plywood. Tape the piece to the leg rabbet. Then, holding the guide, band-saw the leg to shape, as shown at *right*.

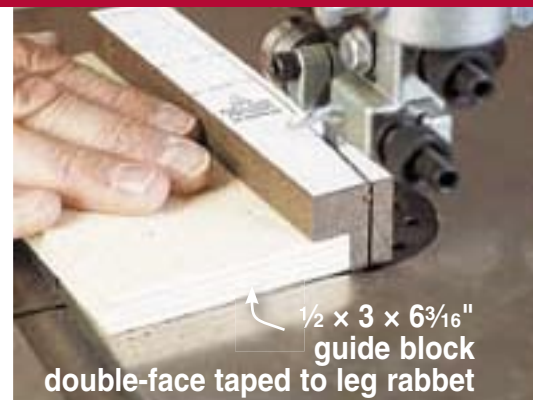

2 PARTS VIEW

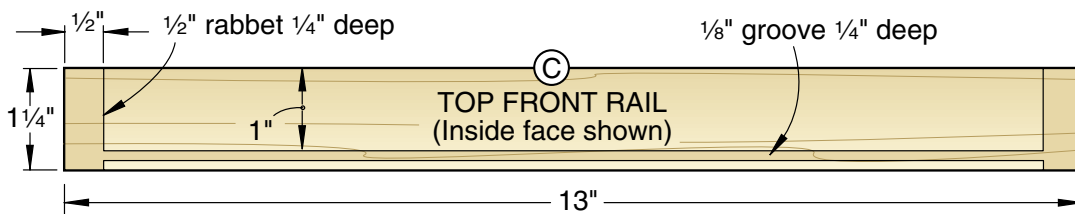
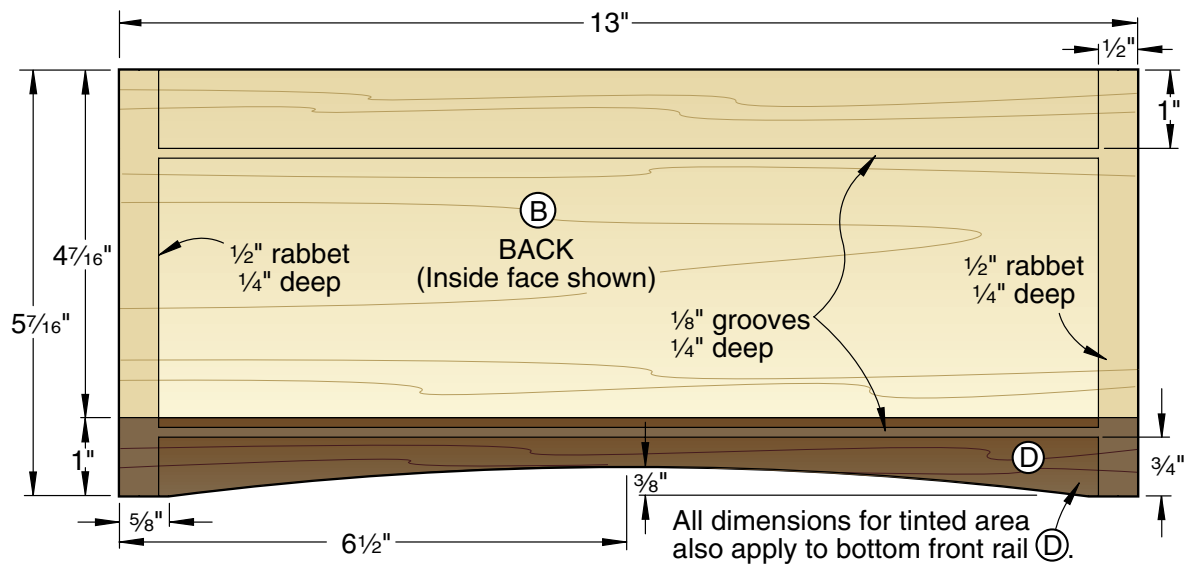
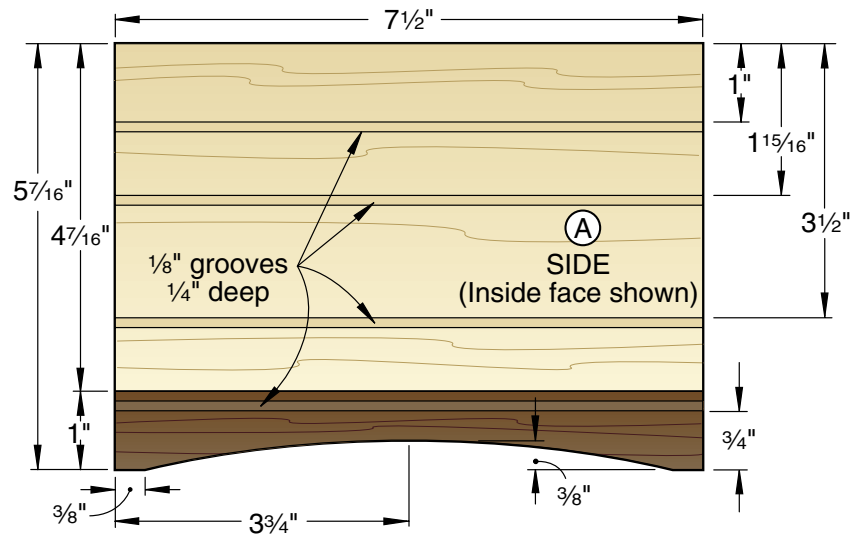

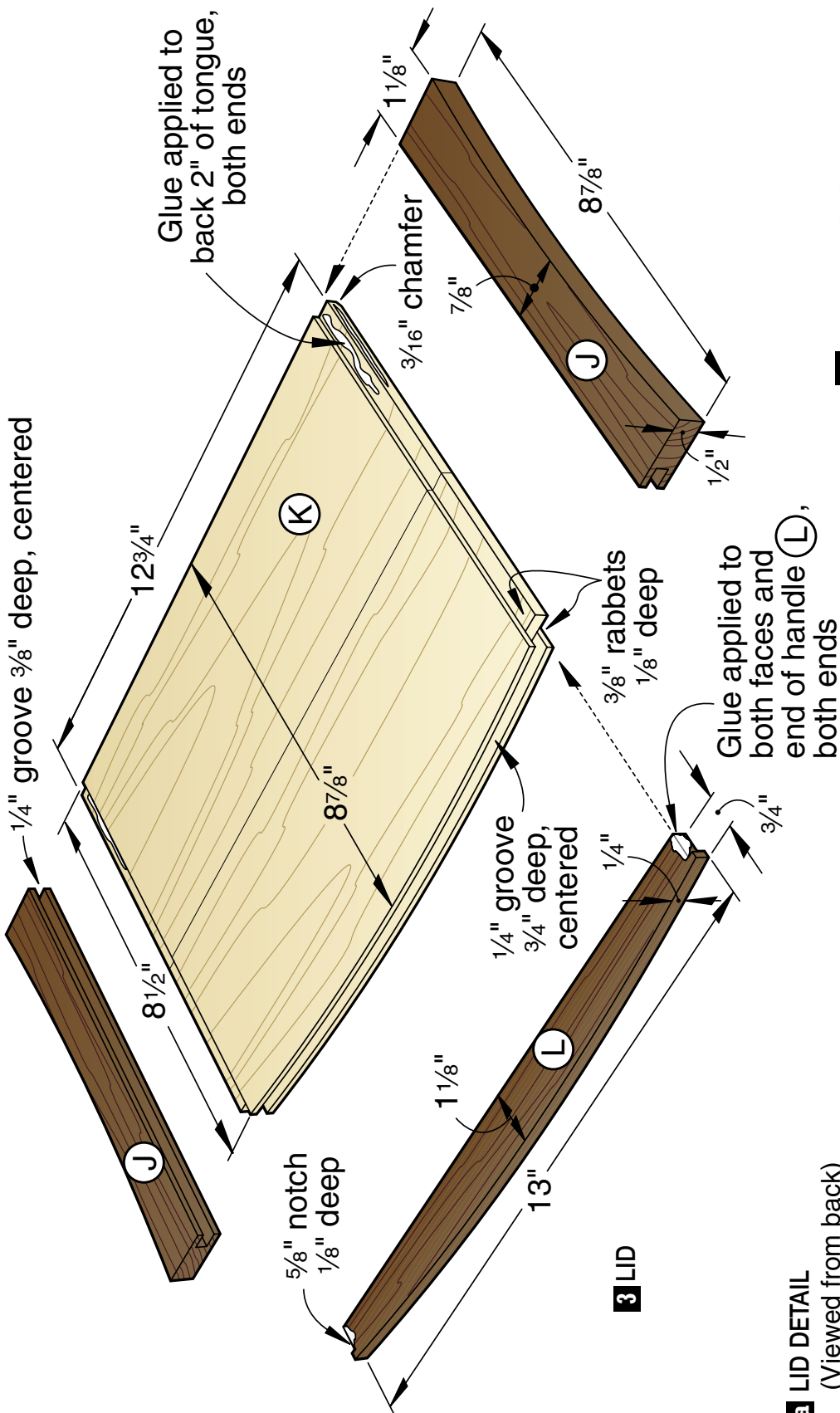

3a LID DETAIL (Viewed from back)

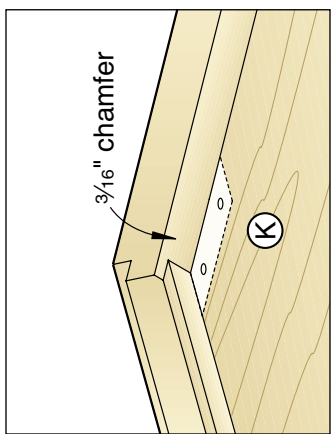

3b HANDLE NOTCH DETAIL

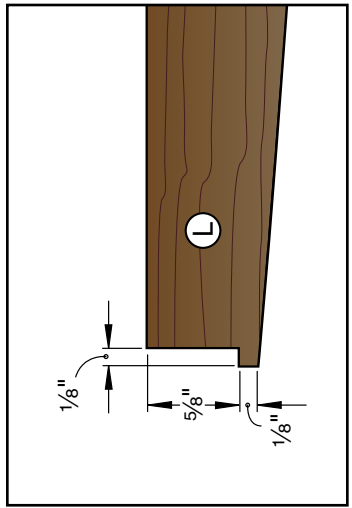

6 Draw the curves along the *outside* edges of the breadboard ends (J) and along the *front* edge of the panel (K), where dimensioned on **Drawing 3**. Then bandsaw and sand the curves to shape.

7 From $\frac{3}{4}$ "-thick wengé resawn or planed to $\frac{1}{4}$ " thick to fit the groove in the panel (K), cut the handle (L) to size. Lay out a $\frac{5}{8}$ " notch $\frac{1}{8}$ " deep at each end of the handle and draw the curve along the *front* edge, where dimensioned on **Drawings 3** and **3b**. Cut the notches using a fine-tooth handsaw. Then bandsaw and sand the curve to shape.

8 To assemble the lid, apply glue to only the back 2" of the tongues on the panel (K) and the areas on the notched ends of the handle (L), as shown in **Photo B**. (Gluing in this manner allows the panel to move freely at the front. A $\frac{1}{8}$ " gap between the handle and the bottom of the groove in the panel accommodates the panel

movement.) Now assemble the breadboard ends (J) on the panel, flush at the back; install the handle; and clamp the assembly together, as shown. Remove the squeeze-out.

9 From $\frac{3}{4}$ "-thick curly maple resawn or planed to $\frac{5}{16}$ " thick, cut the hinge support (M) to size to fit between the rear legs (H), where shown on **Drawings 1** and **1b**. Lay out the $\frac{1}{4}$ " notches $\frac{5}{32}$ " deep for the $1\frac{1}{4} \times \frac{5}{16}$ " brass full-stop box hinges on the ends of the support, where shown. Bandsaw and sand the notches smooth. Then, with the notches up, glue and clamp the support to the back (B), flush with the top edge.

10 Position the hinges in the notches, where shown on **Drawing 1b**, and mark the center of the mounting holes. Drill pilot holes, and prethread the holes with a #4x $\frac{1}{2}$ " steel flathead wood screw. (This prevents breaking the soft brass screws.) Lubricate #4x $\frac{1}{2}$ " brass flathead wood screws with paraffin wax. Now drive the screws to secure

the hinges. Note that when closed, the hinges sit about $\frac{1}{32}$ " proud of the top edge of the hinge support. This prevents hinge binding so the lid will close flat.

11 To hinge-mount the lid (J/K/L) to the case, where shown on **Drawing 1b**, draw lines for hinge alignment on the *bottom* face of the panel (K). Starting at the joint between each breadboard end (J) and the panel, draw a $1\frac{1}{2}$ "-long line $\frac{1}{2}$ " from the panel *back* edge toward the center.

Next, with the case positioned with the back (B) on a $\frac{1}{2}$ "-thick spacer, align the hinges with the marked lines on the panel and breadboard end/panel joints, as shown in **Photo C**. (If the outside edges of your hinges don't exactly align with the joints, simply center the lid side-to-side.) Mark the mounting holes, and then drill pilot holes. Sand off the marked lines. Now drive the screws to attach the lid, prethreading the holes as before.

ASSEMBLE THE LID PANEL, BREADBOARD ENDS, AND HANDLE

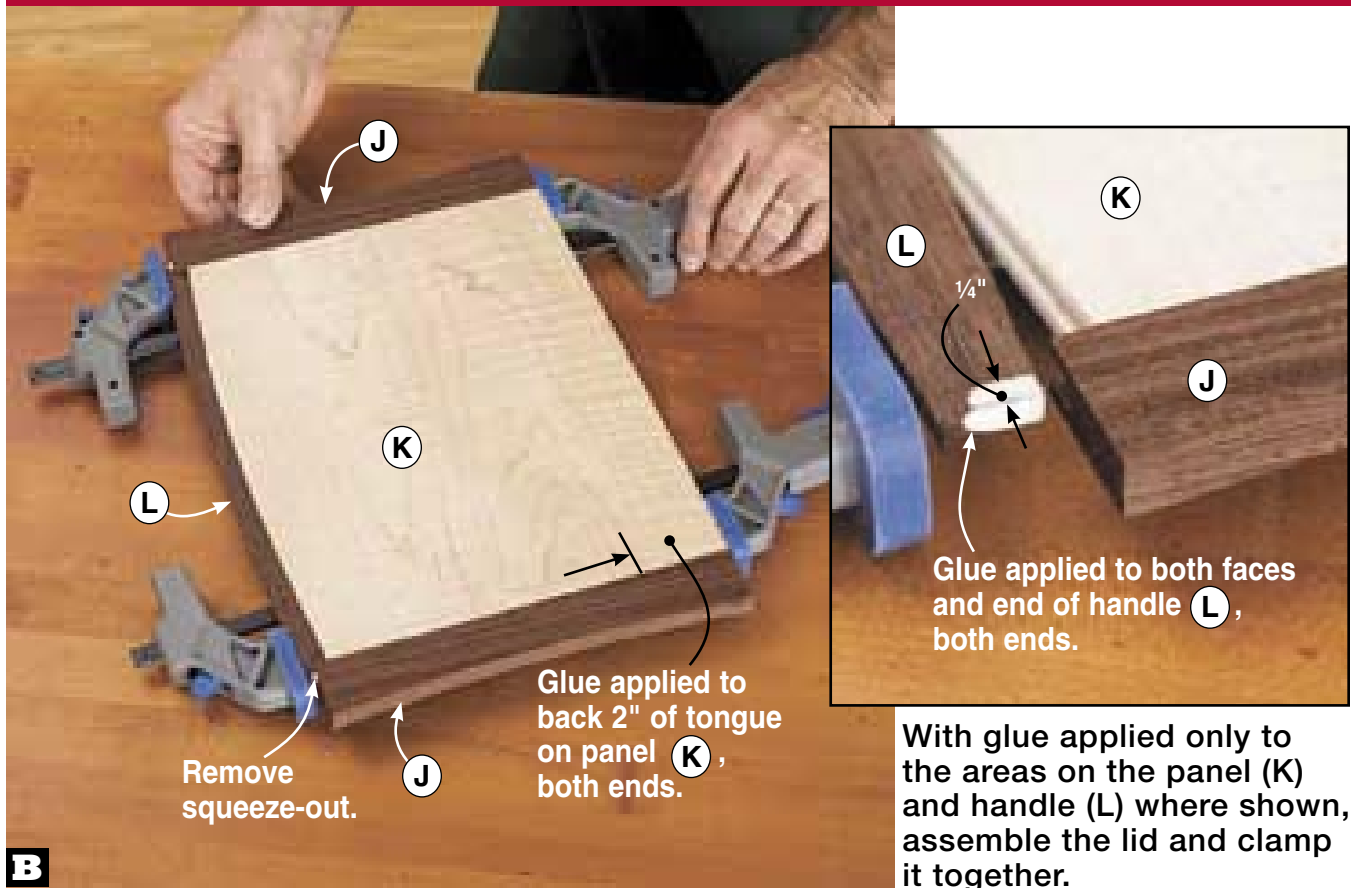

Now let's build a pair of fitting drawers

1 From $\frac{3}{4}$ "-thick maple resawn or planed to $\frac{1}{4}$ " thick, cut four $1\frac{1}{2}\times 10$ " pieces for the drawer sides (N) and two $1\frac{1}{2}\times 11\frac{5}{8}$ " pieces for the backs (O). Crosscut the drawer sides to the finished length of 7", saving the cutoffs. You'll use these for making test-groove cuts to correctly position the drawers on the drawer runners (G) in the case.

2 From $\frac{3}{4}$ "-thick curly maple planed to $\frac{1}{2}$ " thick, cut the fronts (P) to size.

3 Using a standard blade in your tablesaw, cut a $\frac{1}{8}$ " groove $\frac{1}{8}$ " deep $\frac{1}{8}$ " from the *bottom* edge of the sides (N), backs (O), and fronts (P) to fit your $\frac{1}{8}$ " hardboard for the bottoms (Q), where shown on **Drawing 4**. Switch to a $\frac{1}{4}$ " dado blade. Then cut a $\frac{1}{8}$ "-deep dado on the *inside* face of the sides (N), where dimensioned, to fit the backs (O). Now cut a $\frac{1}{4}$ " rabbet $\frac{1}{4}$ " deep on the *inside* face of the fronts (P) at both ends to fit the sides and along the *top* edge on the *outside* face to receive the handles (R).

4 To establish a $\frac{1}{16}$ " reveal between the drawers and the case at the top and bottom, cut a $\frac{1}{8}$ " groove $\frac{1}{8}$ " deep $\frac{3}{4}$ " from the *bottom* edge of a drawer-side cutoff, where dimensioned on **Drawing 4**. Bandsaw and sand the handles to shape. Then glue and clamp them to the rabbets in the drawer fronts (P), keeping the ends flush.

5 Position one of the bottom sides (N) in the case. Then position the grooved cutoff above it. Check for $\frac{1}{16}$ " clearance below and above the cutoff. Again, adjust your set-up if needed. Then cut the $\frac{1}{8}$ " grooves in the remaining side pieces. Mark the bottom edges, and identify the parts as "top."

6 From $\frac{1}{8}$ " hardboard, cut the drawer bottoms (Q) to $5\frac{3}{4}\times 11\frac{5}{8}$ ". Sand all of the drawer parts, except the hardboard, to 220 grit. Then glue and clamp the drawers together, verifying correct orientation of the sides (N) and checking for square.

7 From $\frac{3}{4}$ "-thick wengé resawn or planed to $\frac{1}{4}$ " thick, cut the handles (R) to size. Mark the curve on the handles, where dimensioned on **Drawing 4**. Bandsaw and sand the handles to shape. Then glue and clamp them to the rabbets in the drawer fronts (P), keeping the ends flush.

8 Noting the marked locations, slide the drawers into the case. Check for an equal $\frac{1}{16}$ " reveal on each side of the drawers, and verify they slide freely, but without looseness. If needed, remove the drawer runners (G), and sand them or cut new ones to achieve the desired fit. Then glue the runners in place in the case grooves.

easy way to set the spacing, see the **Shop Tip**, below. If necessary, adjust your setup. Then cut the grooves on the *outside* faces of two drawer sides (N). Mark the bottom edges and identify the parts as "bottom" to ensure correct orientation during drawer assembly and location of the drawer in the case.

HINGE-MOUNT THE LID

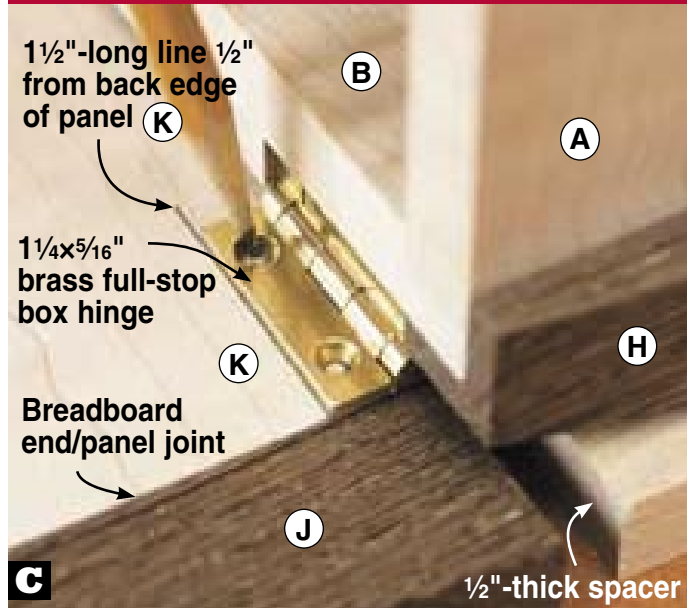

Align the case hinges with the marked lines on the lid panel (K) and the breadboard end (J) and panel joints. Mark the mounting holes.

SHOP TIP

Nickels serve as handy spacers

Using a ruler to check for $\frac{1}{16}$ " spacing between parts, such as the jewelry box drawers, can be cumbersome. Here's an easy way to establish uniform reveals without measuring. Simply place nickels, which measure a smidgen over $\frac{1}{16}$ " thick, between the parts to set the spacing, as shown.



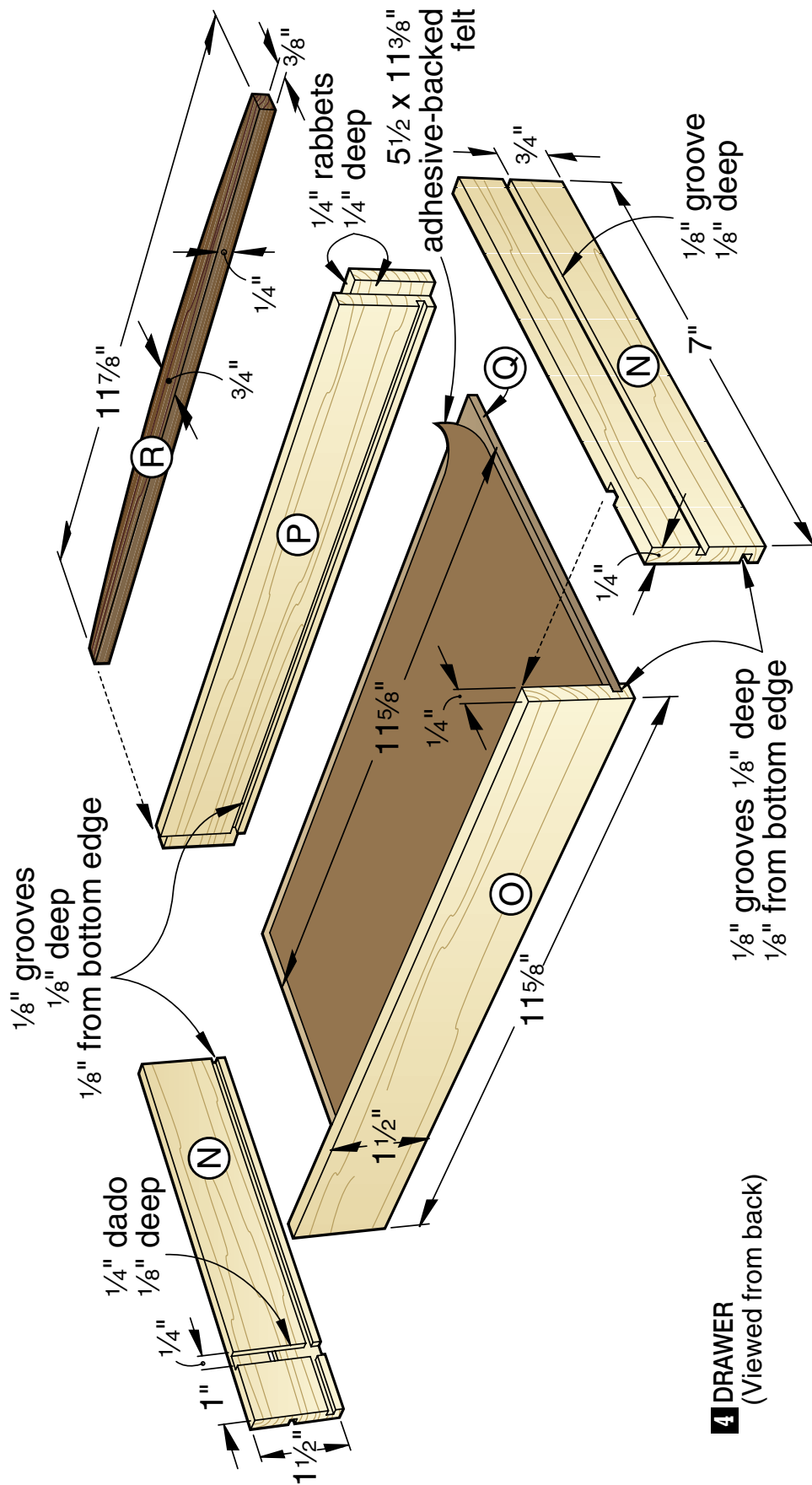

4 DRAWER
(Viewed from back)

Time to apply the finish and install the felt

1 Remove the lid, hinges, and drawers from the case. Sand any areas that need it to 220 grit, and remove the dust. Then apply a clear finish of your choice. To make the figure in the curly maple pop, see the sidebar, “A great finish for fancy-grain figured woods,” *below*.

2 Cut pieces of adhesive-backed felt (we used a brown color) to fit the top panel (E) and bottom of the legs (H), where shown on **Drawing 1**, and the drawer bottoms (Q), where shown on **Drawing 4**. Remove the backing, and press the felt pieces into place.

3 Finally, reattach the lid and slide in the drawers. Now, head for a jewelry store, pick out a nice item for the box,

and surprise a lucky recipient with your thoughtfulness and handiwork. ♣

Produced by **Marlen Kemmet**
Written by **Owen Duvall** with **Chuck Hedlund**
Project design: **Jeff Mertz**
Illustrations: **Roxanne LeMoine**
Graphic design: **Lorna Johnson**

The purchase of these plans does not transfer any copyright or other ownership interest in the plans, the design, or the finished project to the buyer. Buyer may neither reproduce the plans for sale nor offer for sale any copies of the finished project.

A great finish for fancy-grain figured woods

You don't need to use an elaborate finishing technique to bring out the prized grain in figured woods, such as the curly maple for the jewelry box. Here's a simple process Master Craftsman Chuck Hedlund uses to achieve eye-catching results.

Liberal apply a coat of boiled linseed oil to the wood, and after 10 minutes wipe off the excess with a clean cloth. Because the various portions of figure absorb the oil at different rates, it enhances the contrast. Let the oil dry for at least a week. Then apply four *light* coats of a clear finish, such as Deft aerosol lacquer Semigloss Clear Wood Finish, sanding to 320 grit between the first three coats and 400 grit before the final coat. (We used a lacquer finish because it dries fast and sands easily.) Spraying light coats avoids runs, sags, and an “orange peel” appearance.

Materials List

Case		FINISHED SIZE			Matl.	Qty.
		T	W	L		
A*	sides	1/2"	5 7/16"	7 1/2"	EM/W	2
B*	back	1/2"	5 7/16"	13"	EM/W	1
C	top front rail	1/2"	1 1/4"	13"	CM	1
D	bottom front rail	1/2"	1"	13"	W	1
E	top and bottom panels	1/8"	7 1/2"	12 1/2"	H	2
F	front fillers	1/4"	1/2"	3 3/16"	W	2
G	drawer runners	1/8"	7/16"	7 1/4"	H	4
H*	legs	15/16"	15/16"	6 3/16"	LW	4
I*	leg fillers	1/2"	1/2"	3/4"	W	4
Lid						
J	breadboard ends	1/2"	1 1/8"	8 7/8"	W	2
K*	panel	1/2"	8 7/8"	12 3/4"	ECM	1
L	handle	1/4"	1 1/8"	13"	W	1
M	hinge support	5/16"	3/4"	12"	CM	1
Drawers (2 needed)						
N*	sides	1/4"	1 1/2"	7"	M	4
O	backs	1/4"	1 1/2"	11 5/8"	M	2
P	fronts	1/2"	1 1/2"	11 7/8"	CM	2
Q	bottoms	1/8"	5 3/4"	11 5/8"	H	2
R	handles	1/4"	3/4"	11 7/8"	W	2

*Parts initially cut oversize. See the instructions.

Materials key: EM/W—edge-joined curly maple and wengé, CM—curly maple, W—wengé, H—hardboard, LW—laminated wengé, ECM—edge-joined curly maple, M—maple.

Supplies: Spray adhesive; cloth-backed double-faced tape; #4x1/2" steel flathead wood screw (1) and #4x1/2" brass flat-head wood screws (8); paraffin wax; 9x12" adhesive-backed brown felt (3), available at craft and fabric supply stores, such as Michaels and Jo-Ann.

Blade and bit: Dado-blade set, 45° chamfer router bit.

Sources

Hinges: 1 1/4x5/16" full-stop box hinges (1 pr.) no. 01B03.02, call for current price. Call or click Lee Valley, 800/871-8158; leevalley.com.

Kits: For hardware and lumber/hardware kits for the jewelry box, call or click Heritage Building Specialties, 800/524-4184; heritagewood.com.

Cutting Diagram

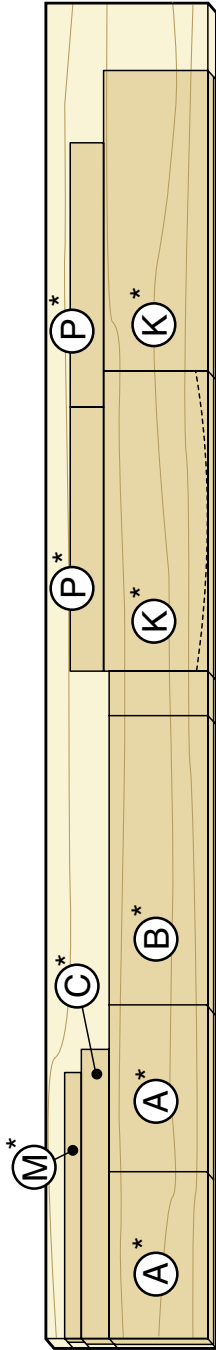

3/4 x 7 1/4 x 60" Curly maple (3.3 bd. ft.)

*Plane or resaw to the thicknesses listed in the Materials List.

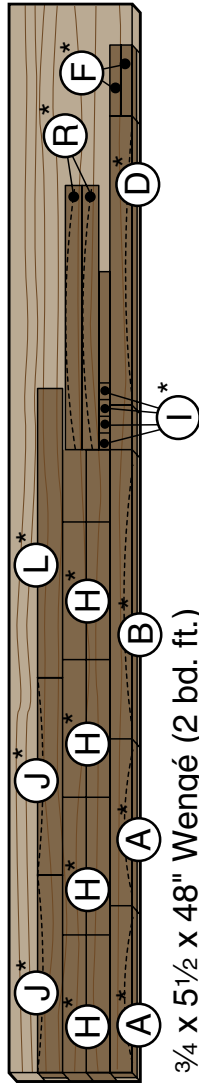

3/4 x 5 1/2 x 48" Wengé (2 bd. ft.)

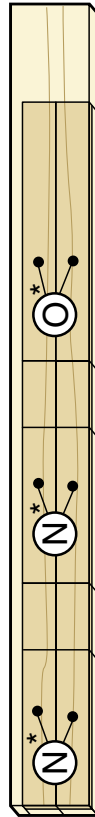

3/4 x 3 1/2 x 36" Maple (1 bd. ft.)

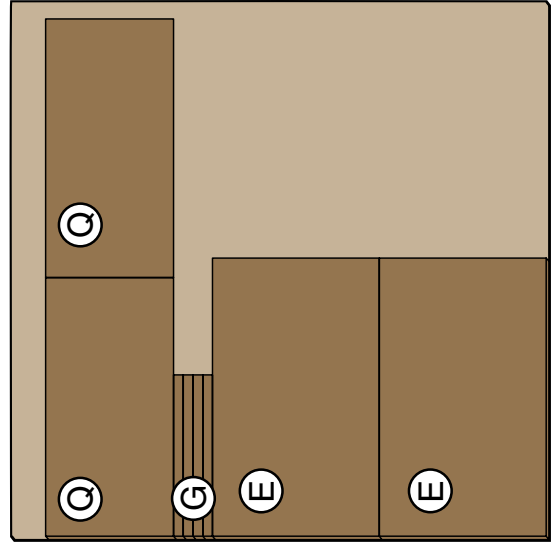

1/8 x 24 x 24" Hardboard

FULL-SIZE PATTERN

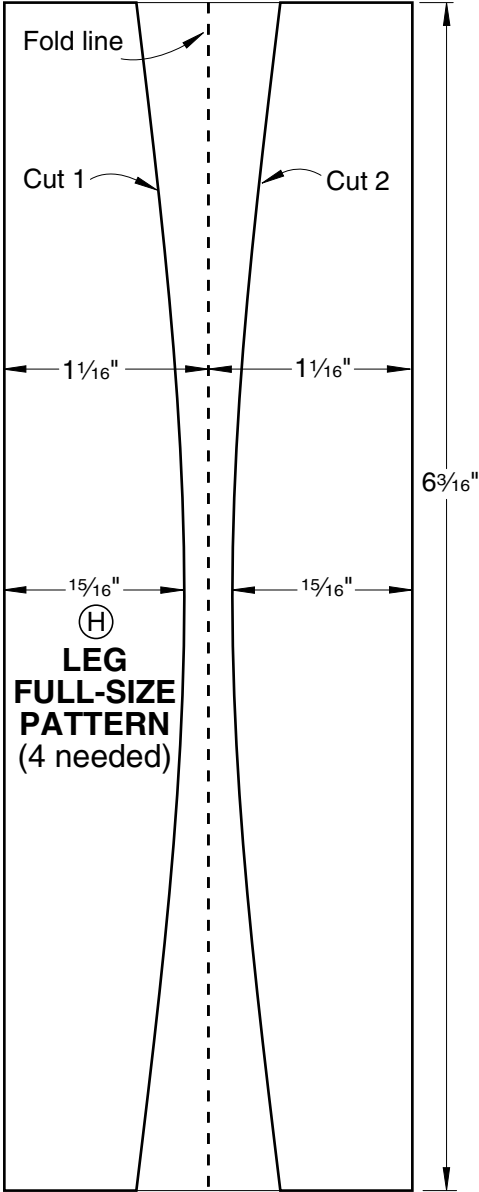

To ensure full-size patterns are correct size, your printer should be set to print at 100% (not fit to page). Measure full-size patterns to verify size.

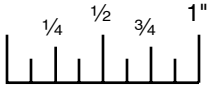

More from WOOD Magazine

WOODStore.net

Browse more than 1,000 woodworking project plans, articles, tool reviews, books, techniques, & more. Each plan includes step-by-step instructions, professional color photography, and detailed illustrations.



Plans

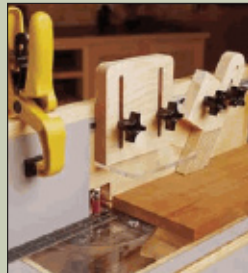

Techniques



Articles



Publications

WOODmagazine.com

A WEALTH OF INFORMATION JUST A CLICK AWAY

The online presence of WOOD magazine, WOODmagazine.com speaks to online users of all woodworking skill levels with free woodworking plans, helpful forums, numerous articles, to help you become a better woodworker.



WOODWorkersCenter.com

LOOKING FOR INFORMATION FROM LEADING WOODWORKING COMPANIES?

WOODWorkersCenter.com is just the site for your woodworking tool, accessory, and service informational needs. Use the online info request feature to request these companies latest catalogs or info.



WOODmagazine.com/videos



PROFESSIONAL, PORTABLE VIDEO
The biggest names in woodworking help you build your skills with downloadable videos.



FREE MAGAZINE SUPPORT 24/7
WOOD magazine editors provide more than 120 streaming videos, from 2 to 10 minutes in length.



BY WOODWORKERS, FOR WOODWORKERS
Watch free videos of other woodworkers showing their stuff.



WATCH A DEMO BEFORE YOU BUY
Don't spend a penny on a tool or accessory until you learn how it works and what it can do.